



WEST VIRGINIA BRIDGE DESIGN & BUILD CONTEST 2019 OFFICIAL RULES

CONTEST SPONSORS



TABLE OF CONTENTS

1	WEST VIRGINIA BRIDGE DESIGN & BUILD CONTEST INFORMATION	3
1.1	Overview	3
1.2	Oversight and Coordination	3
1.3	Rules & Eligibility	3
1.4	Contest Schedule.....	4
2	QUALIFYING ROUND	5
2.1	Bridge Designer Software.....	5
2.2	Requesting Classroom Visits	5
2.3	Team Registration	5
2.4	Bridge Design Software and File Submission	5
2.5	Finalist Selection.....	6
3	FINALS	6
3.1	Bridge Design Contest	6
3.1.1	Team Composition	6
3.1.2	Competition	6
3.1.3	Judging	7
3.2	Balsa Bridge Build Contest	7
3.2.1	Balsa Bridge Kits.....	8
3.2.2	Team Composition	8
3.2.3	The Problem.....	8
3.2.4	The Challenge.....	8
3.2.5	Truss Bridge Specifications.....	8
3.2.6	Final Round	9
3.2.7	Notes to Team Mentors.....	10
4	Disclaimer.....	10

1 WEST VIRGINIA BRIDGE DESIGN & BUILD CONTEST INFORMATION

1.1 Overview

The West Virginia Bridge Design & Build Contest is a statewide contest intended to conduct outreach to middle school and high school students in the area of civil engineering. The contest primarily covers bridge design, but teams invited to the Finals will also have the opportunity to compete in a bridge building contest.

The Qualifying Round of the 2019 West Virginia Bridge Design & Build Contest will run from Monday, September 24, 2018 until Sunday, March 31, 2019 at 11:59 p.m. All individuals/teams must register at www.wvbridgedesignandbuildcontest.com. This will ensure that the correct information is available to contact the finalists. All bridge design files must be uploaded to this website to officially enter the contest.

Approximately the top 25 individuals/teams with the lowest cost designs will be invited to participate in the Finals that will take place on Saturday, May 18, 2019, at Marshall University in Huntington, WV. Finalists will be notified by Friday, April 5, 2019.

The individuals/teams that accept their invitation to the Finals will receive two balsa wood kits in the mail, one with colored balsa wood for a test bridge and one with unfinished balsa wood to construct their bridge for the final competition.

1.2 Oversight and Coordination

The Appalachian Transportation Institute at Marshall University is coordinating the 2019 West Virginia Bridge Design & Build Contest on behalf of the West Virginia Department of Transportation – Division of Highways. The 2019 advisory board members are listed in the table below:

Name	Organization
Alex Wriston	St. Albans High School
Brie Salmons	Appalachian Transportation Institute
Greg Michaelson	Marshall University
Jennifer Dooley	West Virginia DOT-DOH
Ryland Musick	West Virginia DOT-DOH
Tricia Ball	Appalachian Transportation Institute

The point of contact for WVBDB 2019 is Tricia Ball. She can be contacted directly with any questions at ballt@marshall.edu or (304) 696-5745.

1.3 Rules & Eligibility

1. Students must be attending a public or private West Virginia school or must be home-schooled at a West Virginia address.
2. Students from grades 6-12 are eligible to participate.
3. Students may compete individually or in teams of two.
4. All eligible students will be placed into one of two contest categories—Middle School or High School—based solely on their grade level. Eligible students in grades 6-8 will be registered in the Middle School Division. Eligible students in grades 9-12 will be

- registered in the High School Division.
5. Teams composed of one high school student and one middle school student will be considered as a high school team for competition purposes.
 6. Students must register on the contest website (www.wvbridgedesignandbuildcontest.com/register).
 7. To officially enter the contest, students must submit at least one bridge design file (<http://www.wvbridgedesignandbuildcontest.com/login/>) that passes the simulated load test.
 8. Students must create their designs using the Bridge Designer 2019 software that can be downloaded from the contest website.
 9. Students are expected to perform their own work during the Qualifying Round and Finals. Students that are caught cheating or exhibiting behavior that is not representative of the contest values of teamwork and honesty may be disqualified at the discretion of the contest advisory board.

1.4 Contest Schedule

The schedule for the 2019 West Virginia Bridge Design & Build Contest is shown in the table below. Registration can be completed at www.wvbridgedesignandbuildcontest.com/register. The Qualifying Round will end on Sunday, March 31, 2019, at 11:59 p.m. EST. The top teams at the end of the Qualifying Round will be invited to participate in the Finals on Saturday, May 18, 2019, in Huntington, WV.

Event	Dates
Registration	September 24, 2018 – March 31, 2019
Qualifying Round	September 24, 2018 – March 31, 2019
Notification of Finalists	April 5, 2019
Deadline to RSVP	April 12, 2019
Balsa Kits Mailed to Finalists	April 15, 2019
Finals	May 18, 2019

2 QUALIFYING ROUND

2.1 Bridge Designer Software

The Bridge Designer 2019 software can be downloaded from www.wvbridgedesignandbuildcontest.com. The bullets below provide an overview of the software use. Additional tutorials are provided on the website:

- Students will be presented with a requirement to design a bridge to carry a given load from a roadway across a river.
- Students may choose from a wide variety of site configurations for their bridge. Each will carry the load in a different way, and each will have a different site cost.
- Students will develop a design for their bridge by drawing a picture of it on the computer.
- Once the design is complete, the software will test the bridge to see if it is strong enough to carry the specified highway load. This test includes a full-color animation showing a truck crossing the designed bridge. If the design is strong enough, the truck will be able to cross the bridge successfully. If not, the structure will collapse.
- If the bridge design collapses, it can be strengthened by changing the types of steel and the sizes of the structural components that make up the bridge, or by changing the configuration of the bridge itself.
- Once the bridge can successfully carry the highway load without collapsing, the student can then refine the design with the objective of minimizing its cost while still ensuring it is strong enough to carry the specified loads.

2.2 Requesting Classroom Visits

Prior to March 1, 2019, teachers may submit a request for an engineering professional to conduct a free classroom visit to explain to students how to use the Bridge Designer 2019 software and teach some aspects of bridge design. The visits may be conducted by an undergraduate engineering student involved in an American Society of Civil Engineer (ASCE) student chapter (e.g., Bluefield State University, Fairmont State University, Marshall University, West Virginia University, or WVU Institute of Technology), a West Virginia Department of Transportation employee, or another professional engineer volunteer.

These assignments will be based on the location of the school and day/time of the requested visit. Requests must be submitted via the contest website under the Teacher Portal.

2.3 Team Registration

Registration for the West Virginia Design & Build Contest must be completed at the contest website: www.wvbridgedesignandbuildcontest.com.

2.4 Bridge Design Software and File Submission

The 2019 West Virginia Bridge Design & Build Contest will utilize Bridge Designer 2019 software. The software can be downloaded from www.wvbridgedesignandbuildcontest.com/resources. Software design files must be uploaded to the contest website to officially enter the contest. Design files will be checked to ensure the bridge design passes the load test.

2.5 Finalist Selection

Approximately the top 25 individuals/teams (teams with the lowest cost designs) will be selected to participate in the Finals. The goal is to have 50 students at the Finals. In order to have a similar number of middle school and high school participants and because students can enter individually or as teams, it is not possible to set an official number of individuals/teams that will advance to the Finals. Twenty-five is given as an estimate and assumes that the 25 least expensive designs constitute team entries and are half middle school and half high school teams.

The Finals will take place on Saturday, May 18, 2019, at Marshall University in Huntington, WV. Finalists will be notified by Friday, April 5, 2019, and have until Friday, April 12, 2019 to accept their invitation.

3 FINALS

The Finals will consist of two separate contests: 1) Bridge Design Contest (which will consist of an one endurance round and one speed round) and 2) Balsa Bridge Building Contest.

3.1 Bridge Design Contest

Individuals/teams will compete in their respective Middle School and High School divisions. The 2019 Bridge Designer software will be utilized to design the lowest cost bridge for two different scenarios to be identified by the judges (e.g., deck material, deck elevation, abutments, etc.). These scenarios will be different than the Qualifying Round, which did not specify the bridge type or other parameters. Awards will be based on the lowest bridge costs from the two rounds (endurance and speed) combined.

3.1.1 Team Composition

The bridge design team competing in the Finals must be the same individuals that competed in the Qualifying Round. If one of the individuals on a team is unable to compete in the Finals, the remaining team member can compete as an individual. Under no circumstances can a team member be substituted.

3.1.2 Competition

The Bridge Design Contest will consist of two rounds of design with a brief intermission between the rounds. Each round will utilize a specific design scenario that is selected by the judges. The following rules will be enforced during the competition:

1. Each individual/team will be seated in front of a primary computer and a backup computer that are both capable of running the Bridge Designer Software. Only one computer can be utilized for the competition. If the primary computer encounters a problem during the competition, notify a judge immediately. Do not start using the backup computer without a judge's permission.
2. The bridge design scenario will be pre-configured on the computers. Individuals/teams are not permitted to change the design scenario during the competition. If the program shuts down and has to be restarted, notify a judge so that they can confirm the scenario is correct after restarting the program.

3. Computer problems are always possible. Therefore, save your design file on the computer desktop when you start designing. Make sure you save the file frequently so that you do not lose your work in the event of a computer malfunction. If a design is lost and unable to be judged, no additional time or other allowances are permitted.
4. Individuals/teams will be given a sheet of paper to record their bridge costs and iteration number. This is for both the individual/team and the judges to keep track of their lowest bridge cost. Judges will periodically record all of the bridge costs and display the live rankings for all participants to see.
5. The bridge design (iteration) that is shown on the screen when the round ends is the design that will be judged. It is the responsibility of the individual/team members to ensure that their lowest cost design is shown and that it passes the load test. If the final design does not pass the load test, a cost of \$9,999,999 will be recorded.
6. It is not feasible to hide the computer monitors from the view of other teams. Therefore, all individuals must keep their eyes on their own screens. Anyone caught looking at another individual/team's screens will result in the disqualification of that individual/team for the entire competition.
7. Cell phones and other personal communication devices are not permitted in the computer lab during the competition. Anyone caught with a device in the room during the competition will be disqualified from the entire competition.
8. Individuals whose behavior is deemed to be inappropriate or unsportsmanlike will be dismissed from the competition and may forfeit any prizes his/her team is eligible to receive.
9. Parents, chaperones, teachers, siblings, or other persons are not permitted in the computer lab or the hallway outside of the computer lab during the Bridge Design Contest.

3.1.3 Judging

The judges will determine the two design scenarios for the High School Division and the two design scenarios for the Middle School Division prior to the competition.

At the conclusion of each design round, judges will record the cost of the bridge design shown on the computer screen. If that bridge design does not pass the load test or if it is determined that the design scenario was not followed, the judges will record a cost of \$9,999,999. Judges' decisions are final.

The combined bridge costs from the two design rounds for each individual/team will be utilized to rank the individuals/teams.

3.2 Balsa Bridge Build Contest

Finalists who accept their invitation to the Finals by the deadline of Friday, April 12, 2019, will be mailed a balsa kit on Monday, April 15, 2019. The kit will contain colored materials to construct a test bridge and unfinished balsa to construct a competition bridge.

Individuals/teams are to construct a single balsa bridge out of plain materials, which will be tested and judged on the day of the Finals. Final bridges containing any colored balsa wood will be excluded from competition. Bridges will be judged on both aesthetics and the amount of weight it will hold before failure.

3.2.1 Balsa Bridge Kits

The balsa bridge kits will be mailed on Monday, April 15, 2019, to the home address provided during registration. For team entrants, balsa kits will be mailed to the team captain. The kit will consist of two bundles of balsa wood (colored for testing and unfinished for competition) and one container of wood glue that is to be used to construct the bridge. Only the materials included in the kit can be used in the construction of the bridge. Please contact Tricia Ball (ballt@marshall.edu; (304) 696-5745) if there is a problem with your supplies as soon as possible upon receiving them.

3.2.2 Team Composition

Only one bridge can be submitted per individual/team. The Balsa Bridge Build team and the Bridge Design team must be the same individuals. The Bridge Design team is the same team that is registered on the contest website.

3.2.3 The Problem

The goal of this competition is to develop a Truss Bridge that will carry the maximum load while weighing as little as possible (strength-to-weight ratio). It is recommended that each team research the bridge type and design, conduct experiments to test for the highest strength-to-weight ratio, and then design and construct a competition bridge based on those experiments.

Each bridge will be checked for compliance with the Truss Bridge Specifications in Section 3.2.5. The bridges will be weighed and load tested during the competition to calculate strength-to-weight ratio.

3.2.4 The Challenge

An engineer's job is to not only design a safe bridge to carry required loads but also to make sure that it is cost effective (least amount of materials used to support the desired load). The objective is to obtain a high strength-to-weight ratio (example calculation shown below).

Example: Maximum Load Held = 40.0 lbs

Bridge Weight = 20.0 grams

$$\text{Strength-to-Weight Ratio} = \frac{40 \text{ lbs}}{20.0 \text{ grams}} \times \frac{454 \text{ grams}}{\text{lb}} = 908.0 \frac{\text{lbs loading}}{\text{lbs weight}}$$

3.2.5 Truss Bridge Specifications

The bridge must be designed and constructed following these specifications. Violation of these specifications will result in the judges recording zero for the load supported.

1. The unfinished balsa materials provided in the kit are the ONLY materials to be used when building the competition bridge structure (colored wood is for testing only). No modifications to the structural properties of the balsa wood are allowed. Different glue is not allowed.
2. The required dimensions of the bridge are shown in Figure 1. Note that the portion of the bridge that is above the testing apparatus supports is referred to as the superstructure and the portion below the testing apparatus supports is referred to as the substructure. Bridges are not required to have a substructure.

- a) The total length of the bridge shall be 12 inches \pm 0.5 inches.
- b) The total width of the bridge shall be 5 inches \pm 0.5 inches (not shown in Figure 1).
- c) The maximum length of the bridge substructure, if utilized, is 9.5 inches.
- d) The maximum depth of the bridge substructure, if utilized, is 1.0 inch.
3. The bridge shall only touch the top of the supports as shown in Figure 1.
4. A block of wood that is 3.25 inches long by 2.0 inches wide by 0.75 inch high must be able to be pushed across the bridge deck. The block of wood is necessary for load testing the bridge.
5. The bridge deck must incorporate an opening at mid-span to allow a 3/4-inch diameter testing rod to pass through and attach to the wood block (see item 4 above). The rod must be able to pass through the full height of the bridge.
6. Lamination (gluing two pieces of wood along their longitudinal length to increase strength) is not permitted (shown in Figure 2). However, joints may be thicker to accommodate joining wood pieces.

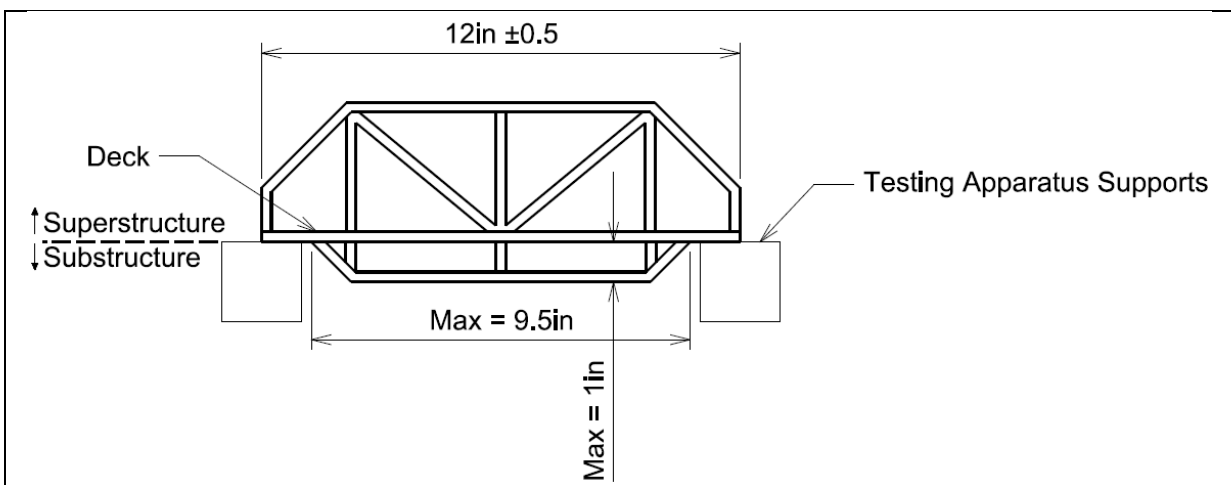

Figure 1. Bridge Dimensions

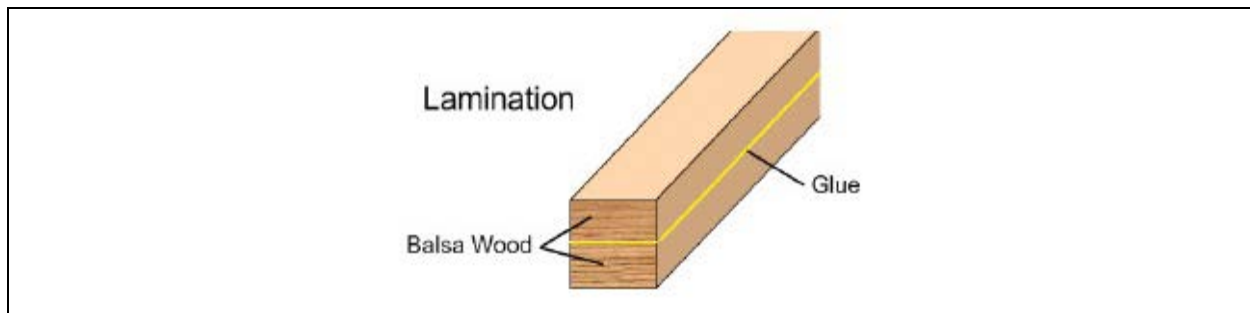

Figure 2. Lamination of Balsa Wood Members is Not Permitted

3.2.6 Final Round

On the day of the Finals, teams will bring their balsa bridges and display them in their designated area. The bridge will remain in that designated area until load testing. The following criteria will be used in judging the bridges:

1. **AESTHETICS:** Judges will evaluate the bridges for quality of construction (e.g., no excess glue, neat cuts, symmetry, etc.) and the resemblance to a truss bridge. The most aesthetic bridge overall will win a prize.

2. **PERFORMANCE:** Bridges will be weighed and then load tested on the Pitsco Tester. Results will be used to calculate strength-to-weight ratio. Any bridge not meeting the Truss Bridge Specifications will result in judges recording zero for the load supported.

3.2.7 Notes to Team Mentors

Work on all phases of the balsa bridge project shall be done by the students. Assistance is to be limited to:

- Mentoring
- Basic guidance of the students
- Teaching engineering, mathematical, and scientific principles applicable to the project
- Guiding students in research
- Assisting in the production of the report and preparation of the drawings
- Overseeing the manufacturing stages of the project

Guidance should be in the form of asking questions (leading questions if necessary) to promote creative thinking by the students to identify the scientific and engineering principles involved. Encourage students to consult credible websites and other resources to help with the project. Encourage students to test and improve their designs. A good way to begin is for each student to design and/or construct a rough prototype, test it, and make improvements.

4 Disclaimer

The contest organizers have made every effort to adequately explain the contest format and corresponding rules within this document. However, they reserve the right to change the rules without notice right up to the Final Round. Any changes will be communicated to the contest participants at the Finals.